

| REVISIONS | | | |
|-----------|-------------|------|-------|
| REV | DESCRIPTION | DATE | APP'D |
| | | | |

To enable light curtain programming, move JP3, JP4, JP5, or JP6 corresponding to the light curtain to be programmed to ENABLE (POS 1).

For scan code B move jumper JP1 to scan B.
Use function button to change parameter code 1 to scan code B.

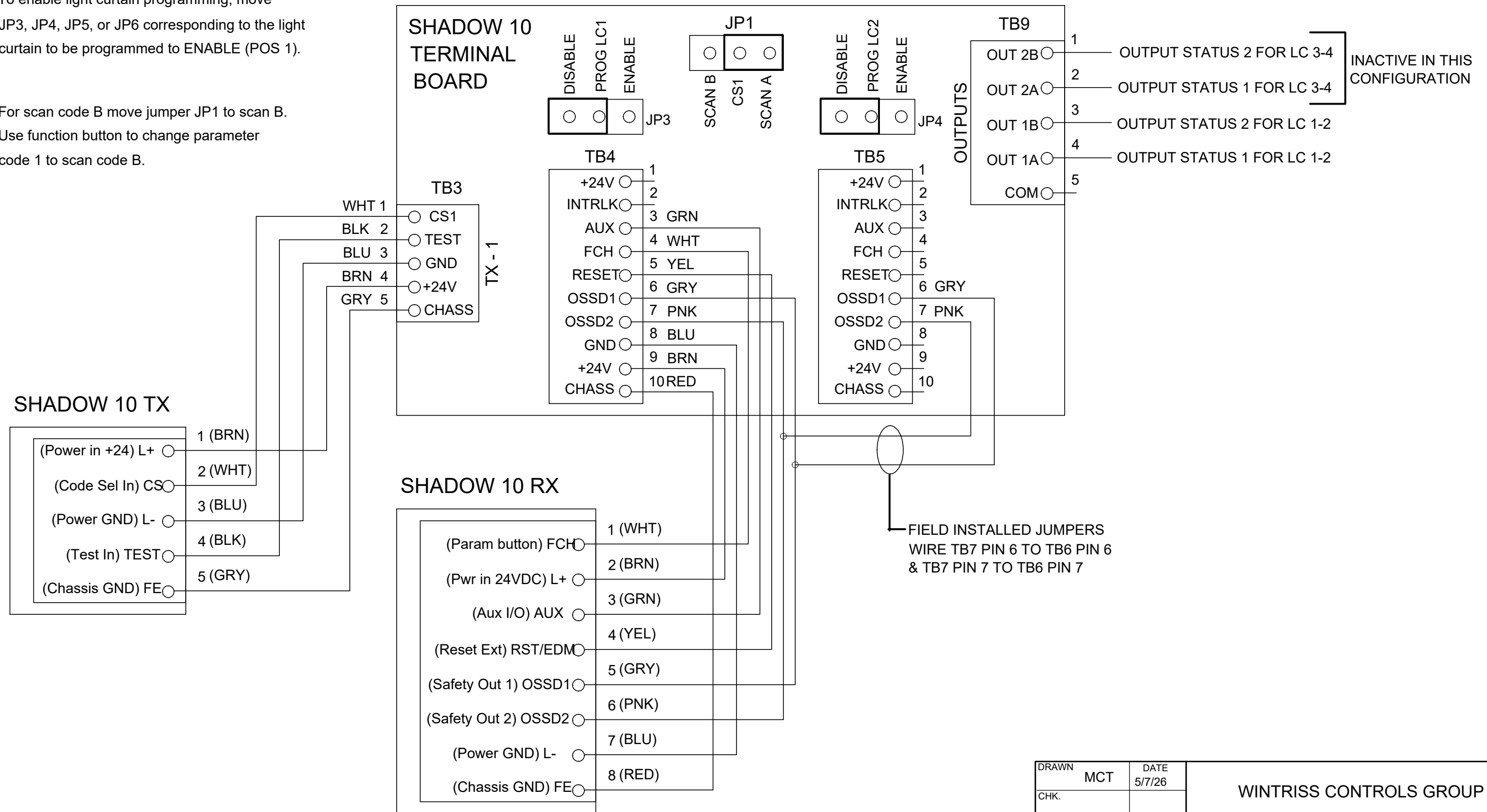

| | | | | | | | |
|-----------|-----|------|--------|---|------|----------------|-----|
| DRAWN | MCT | DATE | 5/7/26 | WINTRISS CONTROLS GROUP | | | |
| CHK. | | | | | | | |
| APPROVALS | | | | TITLE | | | |
| ENG. | | | | SHADOW 10 SINGLE TX AND RX HEAD TO CONTROL BOX WIRING DIAGRAM | | | |
| MFG. | | | | CODE IDENT NO. | SIZE | DRAWING NUMBER | REV |
| REL | | | | | B | FIGURE 1 | |
| SCALE | | | | SHEET | | OF | |