

REVISIONS			
REV	DESCRIPTION	DATE	APP'D

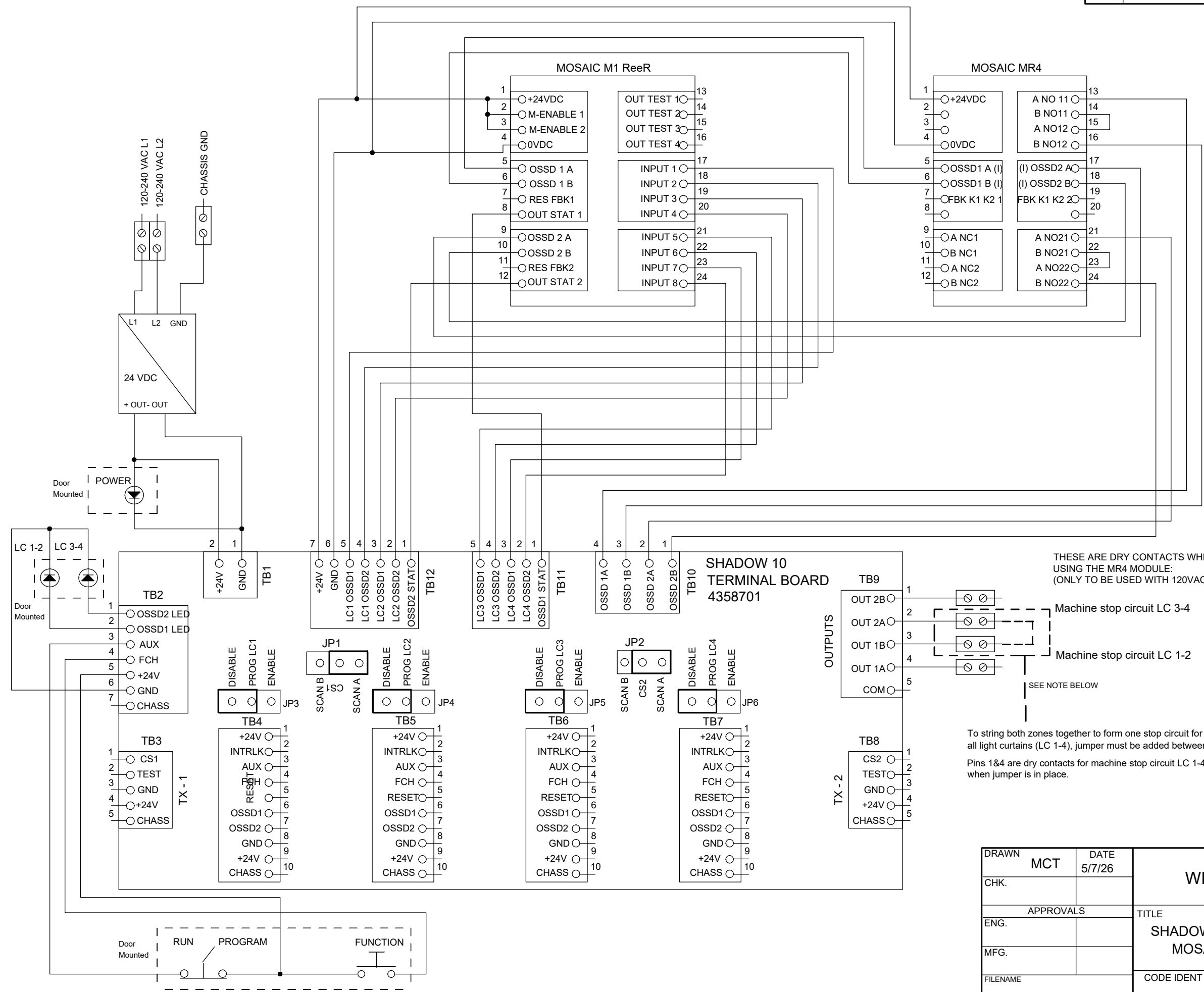

THESE ARE DRY CONTACTS WHEN USING THE MR4 MODULE: (ONLY TO BE USED WITH 120VAC)

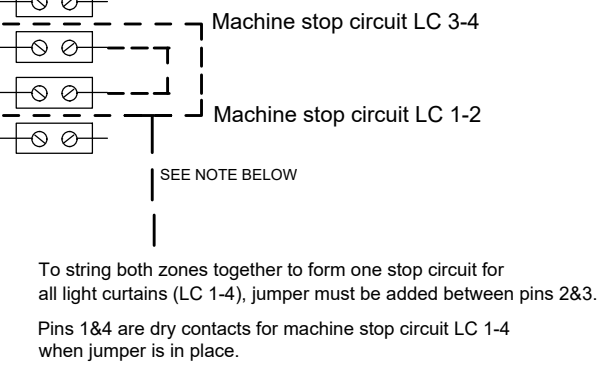

DRAWN	MCT	DATE	5/7/26	WINTRISS CONTROLS GROUP		
CHK.						
APPROVALS				TITLE		
ENG.				SHADOW 10 TERMINAL BOARD WITH M1 to MR4 MOSAIC 1-4 HEADS CONTROL DRAWING		
MFG.				CODE IDENT NO.	SIZE	DRAWING NUMBER
FILENAME					B	FIGURE 9
REL				SCALE		SHEET OF